

Table of Content

Technical and Economic Advantages..... 2

Examples of Customised Extrusions..... 3

Since 1977, apart from its range of standard heat sinks and casings extrusions, Alutronic also offers customised aluminium extrusions. More than 400 customised extrusions have come up since then period and have brought decisive technical and economical benefits to our customers.

If you need any additional information on customised extrusions or like to discuss the feasibility of your ideas, please feel free to contact us. We are glad to be able to help you!



Alutronic delivers large batches quick and efficiently thanks to state-of-the-art twin-spindle technology!



Alutronic offers logistical services, such as recycling packaging customized to your product and quantity.

- Material reduction and reduced need for mechanical machining, e.g. by finished and pressed screw channels
- Slide-in grooves for PCBs or other assembly functions
- Improved cooling power by thermal optimisation of the assembly and convection surface for the specific application
- Integration of plateaus improves the thermal transfer (e.g. as a substitute for gap pads with very large distance to the PCB/component/heat sink or in case the components around the heat source need to be thermally insulated -> as when applying peltier technology)
- Heat sink and housing walls in one part
- Low investment costs. One time tooling cost for extruded profiles are considerably lower than that of e.g. die-cast tools
- Minimum order quantities start with 500 kg
- Stocking of extrusion material for entire order volumes or of materials provided by you.
- Cost reduction for surface finishing. Anodising and chrome-plating for the whole extrusion bar is possible.
- Short lead times times for tool making to prototyping and for serial production.

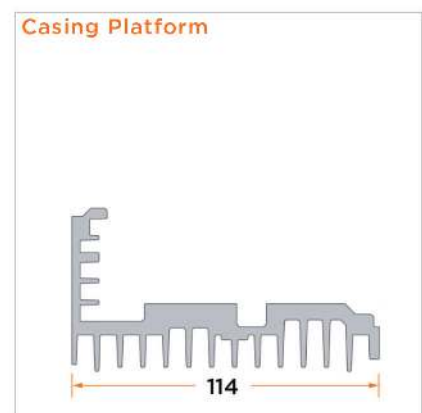
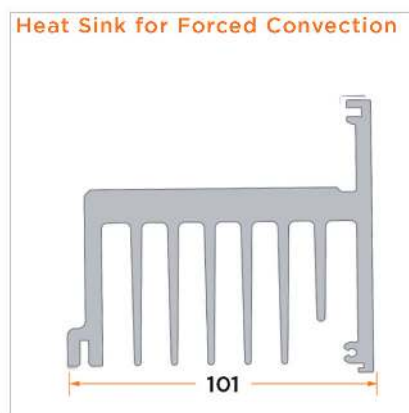
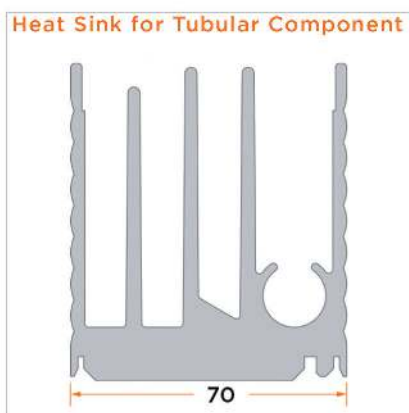
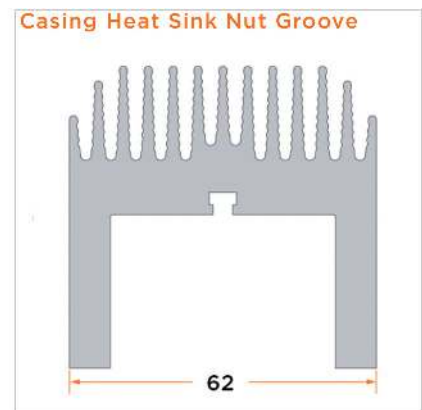
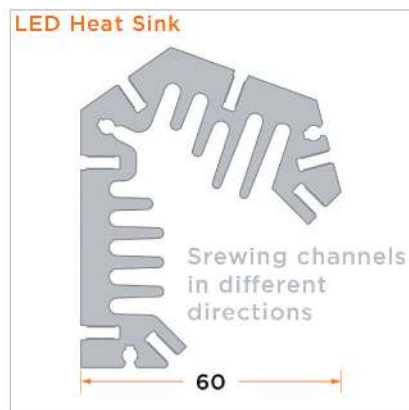
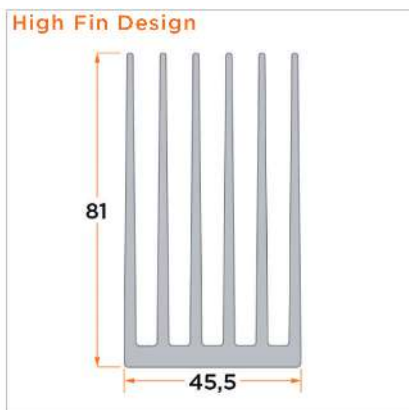

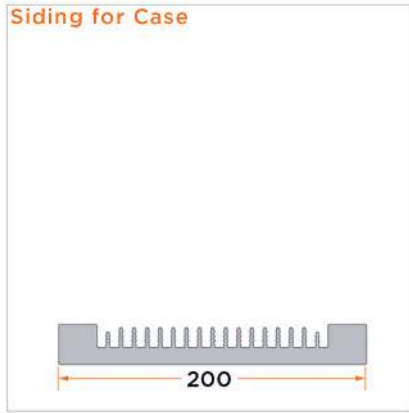
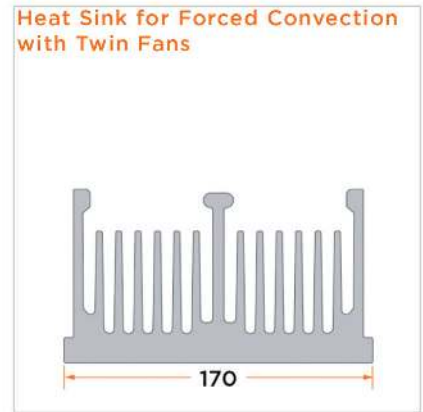
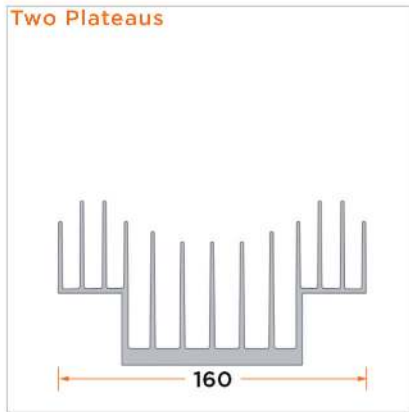
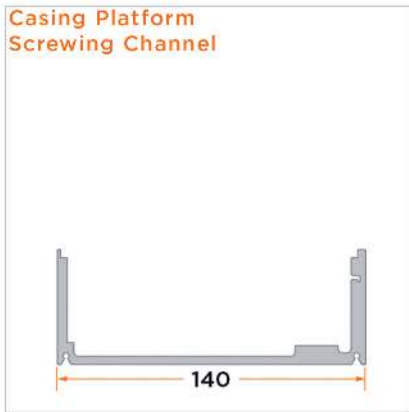
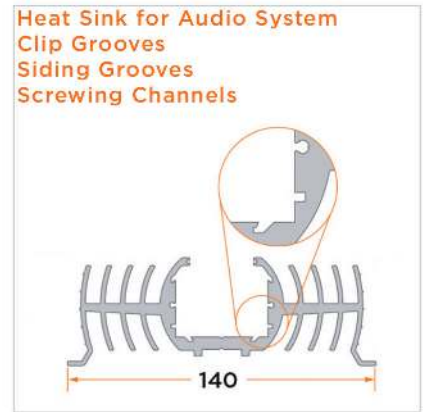
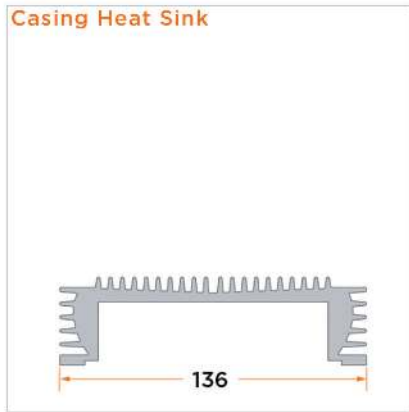
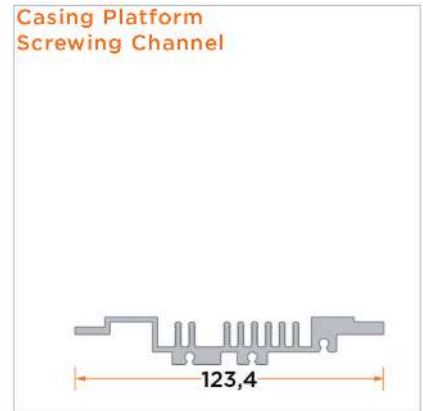
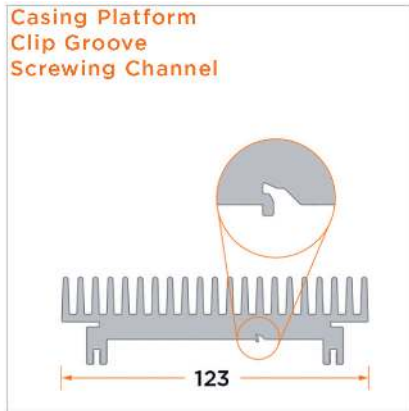
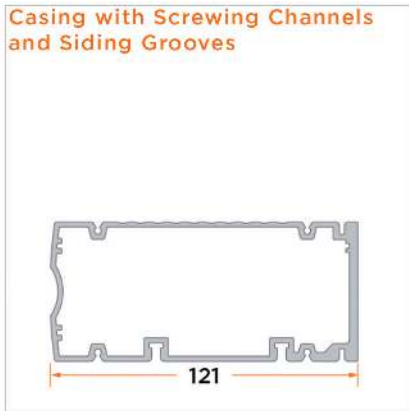



The fastest way to select your standard extrusion:  
The ALUTRONIC EXTRUSION- FILTER at  
[www.alutronic.com/products/heat-sink-profile](http://www.alutronic.com/products/heat-sink-profile)